

Drying Small Grains



West Winfield, NY
February 3, 2015



Kenneth Hellevang, Ph.D., P.E.
Extension Engineer & Professor

NDSU



Department of
Agricultural and Biosystems Engineering
North Dakota State University, Fargo ND

NDSU
Extension Service

Recommended Long-Term Storage Moisture Content



EMC @ 70°F & 60% RH



Grain	EMC	Moisture
Barley	11.8%	12%
Canola	8.0%	8%
Corn	12.8%	13%
Flaxseed	8.3%	8%
Soybeans	10.2%	11%
Sunflower		
Non-Oil	9.6%	10%
Oil	7.4%	8%
Wheat	13.3%	13.5%



Natural Air Drying

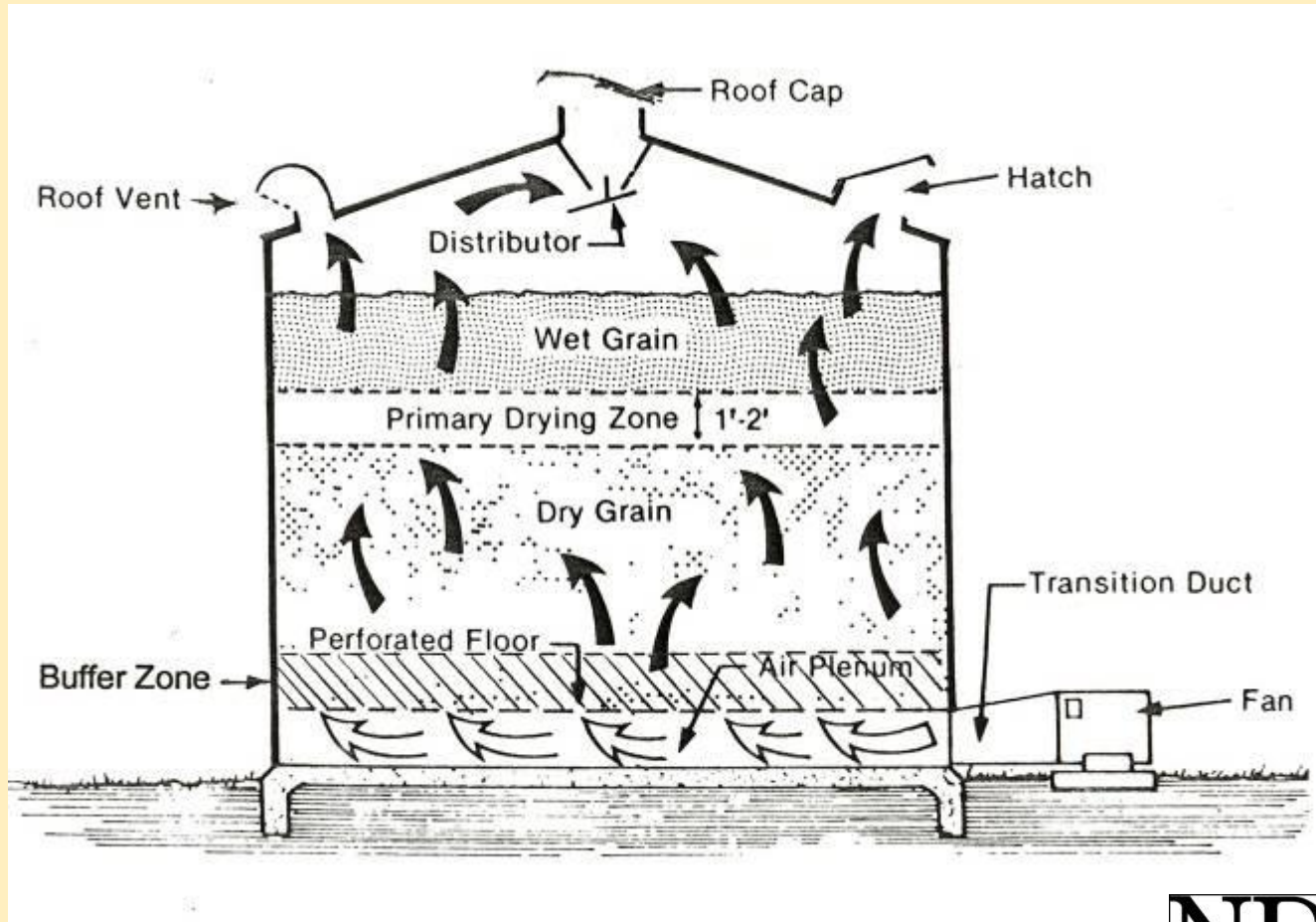

North Dakota Harvest Progression



	Aug			Sep			Oct			Nov
Crop	10	20	30	10	20	30	10	20	30	10
Barley	20	49	77	94	99					
Canola	4	15	36	61	81	92	97			
Corn					2	9	22	43	73	88
Flaxseed		7	20	40	61	79	90	96		
Soybeans					15	46	67	83	93	98
Sunflower						7	21	49	78	90
Wheat	13	34	61	83	94	98	99			
Temperature		69			58			47		27

Climate Comparison, NY v. ND

Syracuse, NY

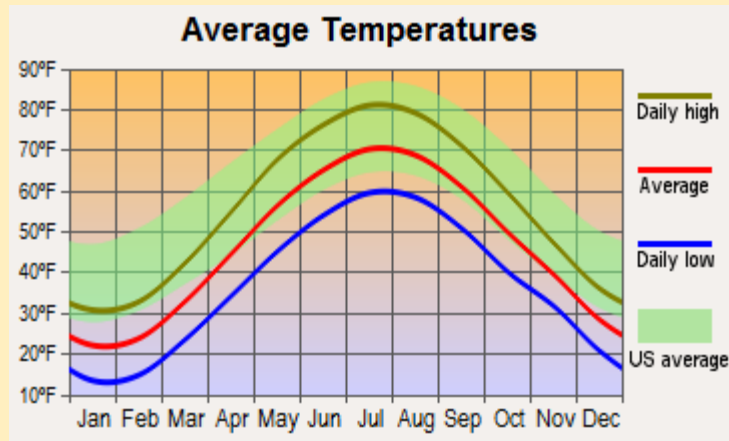

Carrington, ND

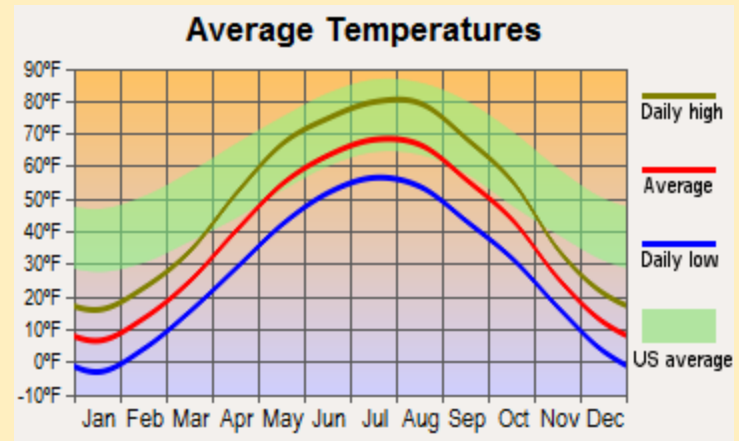

Humidity

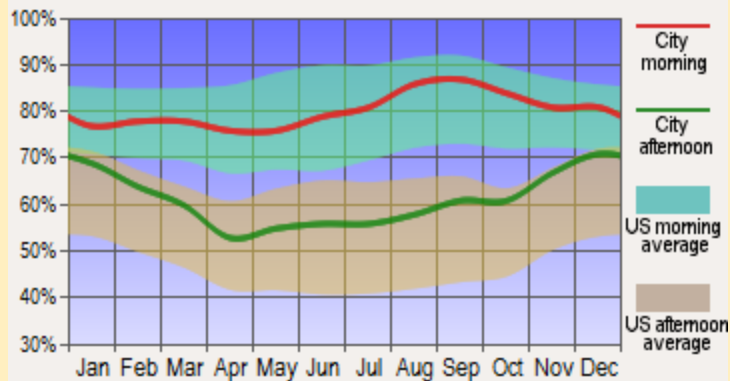

Humidity

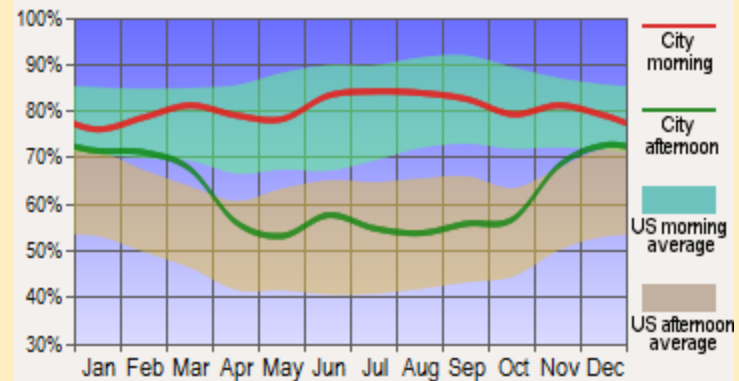

Equilibrium Moisture Content

Barley



EMC = 13.3%



Air

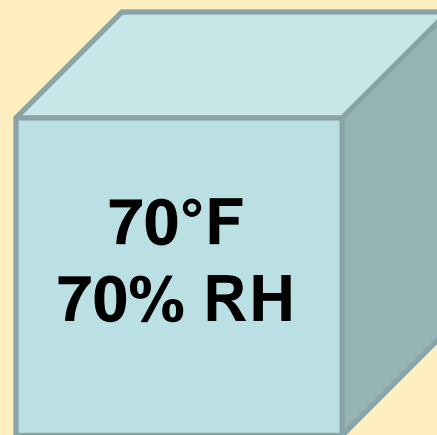

Heat Reduces Air Relative Humidity and Grain Moisture Content

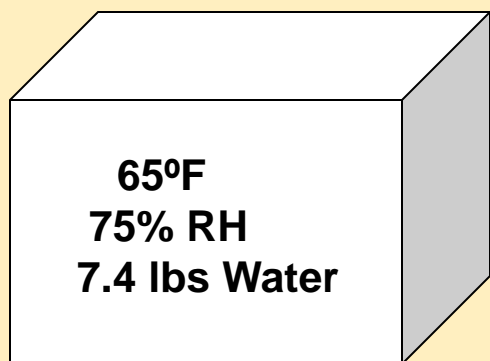

EMC= 15.8%

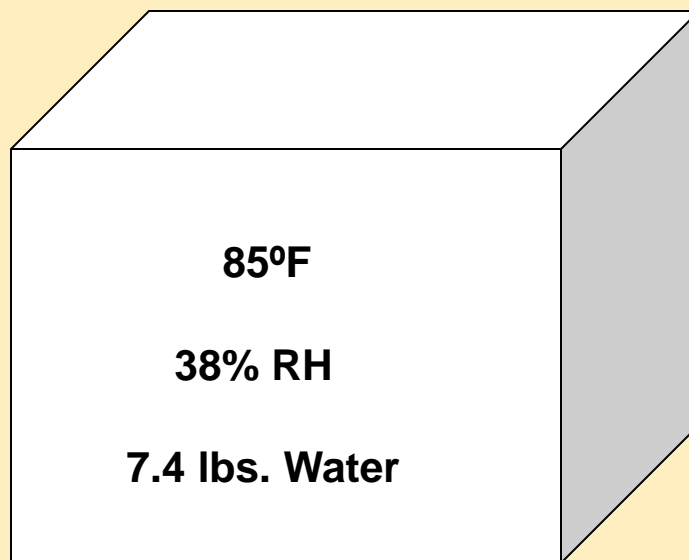

EMC = 10.0%

10,000 cubic feet of air

Equilibrium Moisture Content

Barley



Air

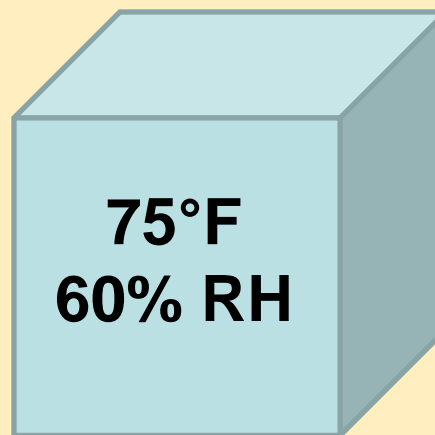

EMC = 11.7%

Running Fans at Night

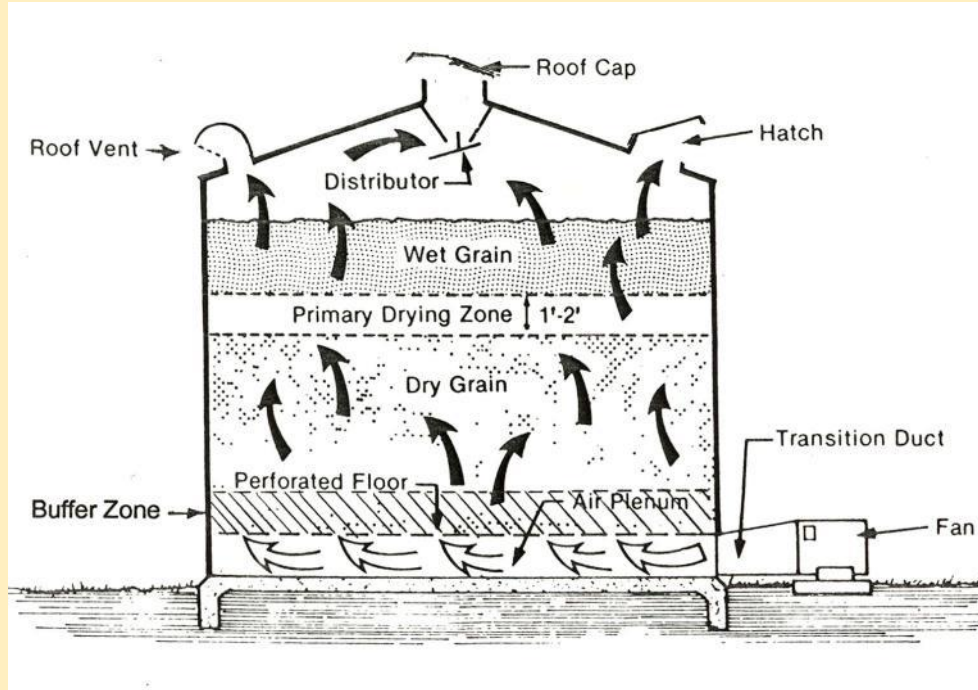

Condition	Temp. (F)	Relative Humidity	E.M.C
Afternoon	80	43%	10.7%
Night	60	85%	17.9%
Average	70	60%	13.3%

Barley Equilibrium Moisture Content

BARLEY EQUILIBRIUM MOISTURE CONTENT																	
TEMPERATURE (°F)																	
	20°	25°	30°	35°	40°	45°	50°	55°	60°	65°	70°	75°	80°	85°	90°	95°	100°
R.H.	MOISTURE CONTENT (% W.B.)																
5%	3.3	3.3	3.3	3.2	3.2	3.2	3.2	3.2	3.1	3.1	3.1	3.1	3.1	3.0	3.0	3.0	3.0
10%	4.7	4.6	4.6	4.6	4.5	4.5	4.5	4.4	4.4	4.4	4.4	4.3	4.3	4.3	4.3	4.2	4.2
15%	5.7	5.7	5.6	5.6	5.6	5.5	5.5	5.5	5.4	5.4	5.4	5.3	5.3	5.3	5.2	5.2	5.2
20%	6.6	6.6	6.5	6.5	6.5	6.4	6.4	6.3	6.3	6.3	6.2	6.2	6.1	6.1	6.1	6.0	6.0
25%	7.5	7.4	7.4	7.3	7.3	7.2	7.2	7.1	7.1	7.0	7.0	7.0	6.9	6.9	6.8	6.8	6.8
30%	8.2	8.2	8.1	8.1	8.0	8.0	7.9	7.9	7.8	7.8	7.7	7.7	7.6	7.6	7.5	7.5	7.5
35%	9.0	8.9	8.8	8.8	8.7	8.7	8.6	8.6	8.5	8.5	8.4	8.4	8.3	8.3	8.2	8.2	8.1
40%	9.7	9.6	9.6	9.5	9.4	9.4	9.3	9.3	9.2	9.1	9.1	9.0	9.0	8.9	8.9	8.8	8.8
45%	10.4	10.3	10.2	10.2	10.1	10.1	10.0	9.9	9.9	9.8	9.8	9.7	9.7	9.6	9.5	9.5	9.4
50%	11.1	11.0	10.9	10.9	10.8	10.7	10.7	10.6	10.6	10.5	10.4	10.4	10.3	10.3	10.2	10.1	10.1
55%	11.8	11.7	11.6	11.6	11.5	11.4	11.4	11.3	11.2	11.2	11.1	11.0	11.0	10.9	10.9	10.8	10.7
60%	12.5	12.4	12.4	12.3	12.2	12.1	12.1	12.0	11.9	11.9	11.8	11.7	11.7	11.6	11.5	11.5	11.4
65%	13.3	13.2	13.1	13.0	13.0	12.9	12.8	12.7	12.7	12.6	12.5	12.5	12.4	12.3	12.3	12.2	12.1
70%	14.1	14.0	13.9	13.8	13.8	13.7	13.6	13.5	13.4	13.4	13.3	13.2	13.1	13.1	13.0	12.9	12.9
75%	15.0	14.9	14.8	14.7	14.6	14.5	14.4	14.4	14.3	14.2	14.1	14.0	14.0	13.9	13.8	13.7	13.7
80%	15.9	15.8	15.7	15.6	15.6	15.5	15.4	15.3	15.2	15.1	15.0	15.0	14.9	14.8	14.7	14.6	14.6
85%	17.1	17.0	16.9	16.8	16.7	16.6	16.5	16.4	16.3	16.2	16.1	16.0	15.9	15.9	15.8	15.7	15.6
90%	18.5	18.4	18.2	18.1	18.0	17.9	17.8	17.7	17.6	17.5	17.5	17.4	17.3	17.2	17.1	17.0	16.9
95%	20.5	20.4	20.3	20.2	20.1	19.9	19.8	19.7	19.6	19.5	19.4	19.3	19.2	19.1	19.0	18.9	18.9

Dr. Kenneth J. Hellevang, PE
NDSU Extension Service
Fargo, ND 58105

“Approximate” Allowable Storage Time for Cereal Grains (Days)

Moisture	----- Grain Temperature (°F) -----					
Content	30°	40°	50°	60°	70°	80°
(%)	Approximate Allowable Storage Time (Days)					
14	*	*	*	*	200	140
15	*	*	*	240	125	70
16	*	*	230	120	70	40
17	*	280	130	75	45	20
18	*	200	90	50	30	15
19	*	140	70	35	20	10
20	*	90	50	25	14	7
22	190	60	30	15	8	3
24	130	40	15	10	6	2
26	90	35	12	8	5	2
28	70	30	10	7	4	2
30	60	25	5	5	3	1

* Exceeds 300 days

Airflow Rates and Drying Times

natural air drying wheat

air at 69° and 60% relative humidity, average North Dakota condition for August.

Moisture Content	Airflow (cfm/bu)	Fan Time	
		Hours	Days
18%	1.25	480	20
	1.00	600	25
17%	1.00	552	23
	0.75	744	31
16%	1.00	504	21
	0.75	672	28
15%	0.50	1,008	42
	1.00	480	20
	0.75	648	27
14%	0.50	960	40
	1.00	408	17
	0.75	544	23
	0.50	816	34

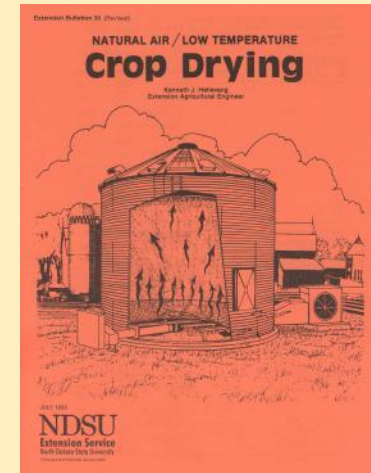

NDSU
Extension Service



Horsepower Required Increases with Airflow Rate

<u>Cfm/bu.</u>	<u>HP</u>	<u>HP/1,000 bu.</u>	<u>Static Pressure</u>
0.5	4	0.4	3
0.75	9	1.0	5
1.0	17	1.8	7
1.5	44	4.8	12

27 ft. diameter bin with barley 20 ft. deep
9,161 bushels

Horsepower Required Increases with Grain Depth

Depth (ft.)	HP	HP/1,000 bu.	Static Pressure (inch H ₂ O)
15	3.5	0.5	2.6
17	5.3	0.7	3.4
19	7.5	0.9	4.4
21	10.4	1.1	5.5
23	14.0	1.3	6.8
25	18.5	1.6	8.2

27 ft. diameter bin of barley with 0.75 cfm/bu. airflow rate



NDSU
Extension Service

Wheat Drying Time



17% initial M.C., 0.75 cfm/bu, +3°F fan

Month	Temp.	RH	+3° Temp	+3° RH	EMC	Days	%↑
Aug.	69	60%	72	54%	12.6%	26	
Sep/ May	58 56	65% 60%	61	58%	13.5%	31	20%
Oct/ Apr	47 42	65% 65%	50	58%	13.9%	39	50%
Nov/ Mar	27 24	73% 73%	30	63%	15.6%	75	300%



Effect of Supplemental Heat Drying Wheat



17% initial M.C., 0.75 cfm/bu, 10,000 bu Bin, \$0.06 electric heat, \$7.00 Wheat

	Temp (°F)	RH (%)	EMC (%)	Drying Time (Days)	Shrink Cost	Heat Cost	Overdry Cost
Ave Sep	58	65	14.4	--			
+3° Fan	61	58	13.5	31			
10° + 3°	71	41	10.8	27	\$2,119	\$940	\$3,059
Ave Oct Cold Sep	47	65	15.0	--			
+3° Fan	50	58	13.9	39			
10° + 3°	60	40	11.0	37	\$1,966	\$1278	\$3,244
Humid Sep	58	75	16.1	--			
+3° Fan	61	67	14.6	40			
10° + 3°	71	47	11.6	28	\$1505	\$968	\$2,473
5° + 3°	66	56	12.9	32	\$482	\$484	\$966

Supplemental Heat

Btu/hr = cfm x 1.1 x temperature increase

Btu/hr = 5,000 x 1.1 x 5

Btu/hr = 27,500 Btu

1 kW = 3,413 Btu/hr

= 8.1 kW



Fan Heat 2-5°F

Wheat Rule of Thumb: 1 Kw heats air 5°F

Mix Dry Grain with Wet Grain

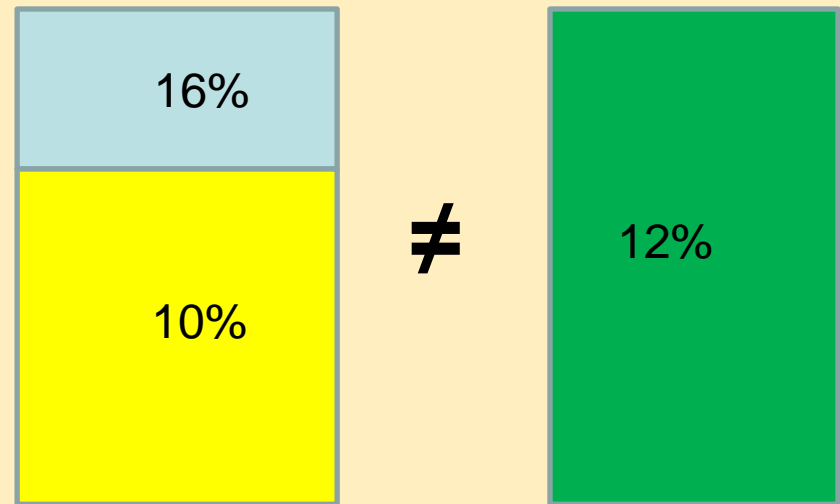
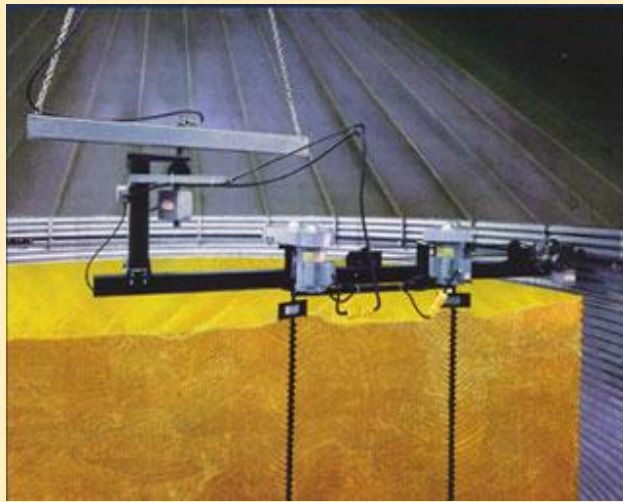

NDSU
Extension Service

Kernel deterioration?
Equilibration Important!!!
Mechanical damage?

Axial-flow Fans

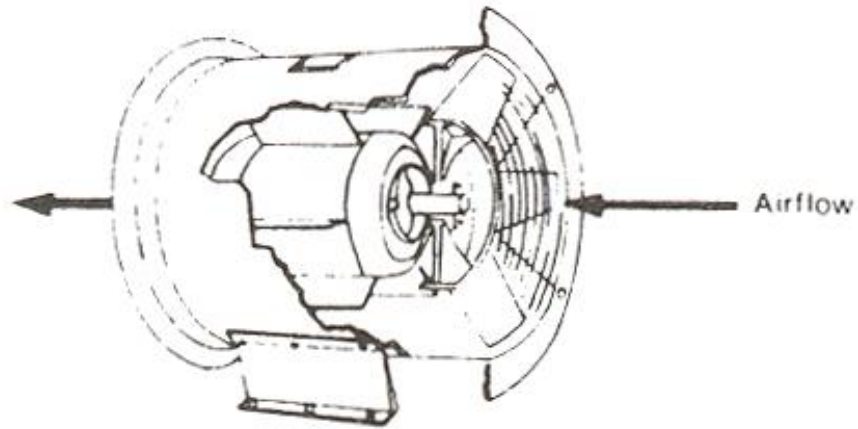

Axial-flow fans operate most efficiently at static pressures below 3 to 4 inches of water. Noise can be a problem.



NDSU
Extension Service

Centrifugal Fans

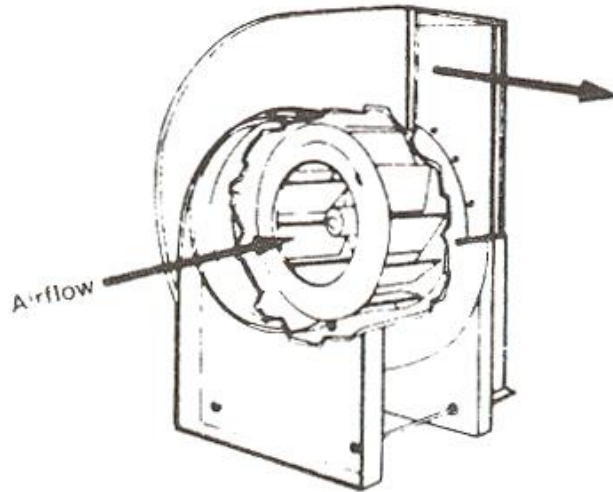

Centrifugal fans require higher investment than axial-flow fans, but are more efficient at higher static pressures and are quieter. They normally operate at 1,750 or 3,500 rpm.

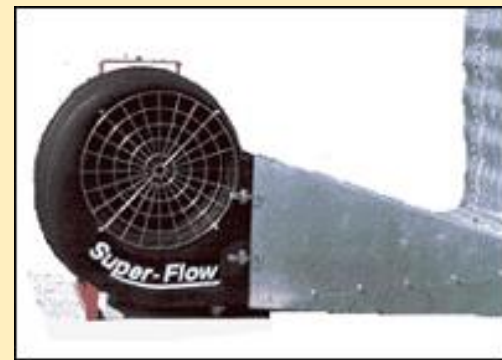

NDSU
Extension Service

In-line Centrifugal Fans

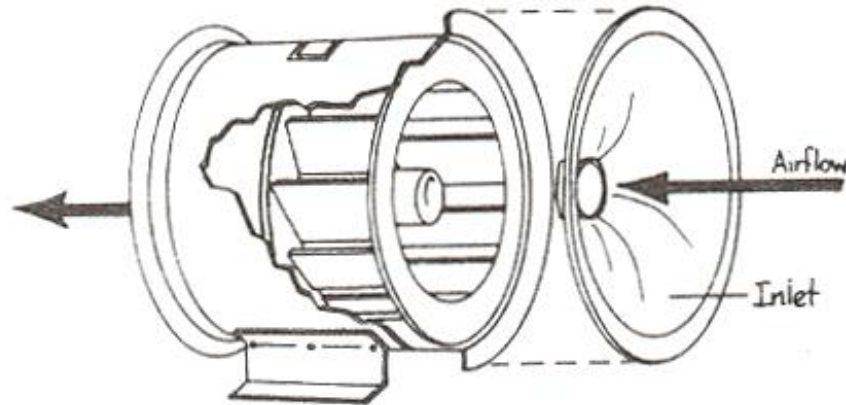

In-line centrifugal fans develop higher pressures than an axial-fan at a lower cost than a normal centrifugal fan.



Typical Fan Performance.

Type	Fan			Static Pressure (Inches of Water)									
	Hp	Dia. (in.)	RPM	1	2	3	4	5	6	7	8	9	10
				Airflow Rate (cfm)									
Axial	3.0	18	3450	5700	4600	2650	1400						
LS Cent.	3.0	24	1750	4580	4230	3820	3350	2550					
HS Cent.	3.0	16	3500		2950		2550		2120		1650		1000
IL Cent.	3.0	18	3450	3800	3600	3400	3000	2500	1900				
IL Cent.	3.0	24	3450	4100	4000	3750	3500	3250	2950	2650			
Axial	5.0	24	3450	10500	9000	7000	4600	2900					
LS Cent.	5.0	24	1750	7800	7000	6250	5550	4600	3300				
HS Cent.	5.0	13	3500		4350		3850		3200		2200		1800
IL Cent.	5.0	24	3450	5500	5000	4400	4100	3900	3600	2800	1800		
Axial	7.5	24	3450	12500	11100	9450	6550	3900					
LS Cent.	7.5	24	1750	10550	9750	8950	8000	7400	6100				
HS Cent.	7.5	15	3500		5700		5100		4500		3800		2900
IL Cent.	7.5	28	3450	6200	6000	5700	5500	5200	4800	4500	4000	3500	3000
Axial	10.0	26	3450	15500	14000	12250	9500	5800	3400				
LS Cent.	10.0	27	1750	13300	12400	11550	10500	9550	8500	7300			
HS Cent.	10.0	18	3500		6800		6300		5750		5100		4450
IL Cent.	10.0	28	3450	7700	7300	6800	6500	6300	6000	5400	5100	4800	4400

LS = Low Speed Centrifugal Fan
 HS = High Speed Centrifugal Fan
 IL = In-Line Centrifugal Fan

* Consult a comparable table for the actual fan being selected.

NDSU
Extension Service



Fan Type Affects Airflow

1 x 7.5 hp LSC = 0.92 cfm/bu

1 x 7.5 hp ILC = 0.97 cfm/bu

1 x 7.5 hp HSC = 0.86 cfm/bu

1 x 7.5 hp Axial = 0.70 cfm/bu

2 x 7.5 hp LSC = 1.40 cfm/bu

2 x 7.5 hp ILC = 1.35 cfm/bu

2 x 7.5 hp HSC = 1.21 cfm/bu

2 x 7.5 hp Axial = 0.80 cfm/bu (in parallel)

2 x 7.5 hp Axial = 1.15 cfm/bu (in series)

21 ft diameter bin with wheat 17.5 ft deep



- Home
 - About Us
 - Undergraduate Programs
 - Graduate Program
 - In the News
 - People
 - Research
 - Career Resources
 - Extension and Outreach
 - Giving
 - Contact Us
-
- College of Food, Agricultural and Natural Resource Sciences
 UNIVERSITY OF MINNESOTA
- COLLEGE OF
 Science & Engineering
 UNIVERSITY OF MINNESOTA
- UNIVERSITY OF MINNESOTA
 EXTENSION

University of Minnesota Fan Selection for Grain Bins

Background [Show Background](#)

Settings [Print](#)

Bin and Crop Inputs

Select a crop:
 Floor Type: Full Duct
 Bin Diameter, feet:
 Grain Depth, feet:
 Desired airflow (cfm/bu):

Estimated Fan Requirements [Show Table](#)

(to get desired airflow when bin is full)

Bin capacity (bushels):	5,542
Total airflow (cfm):	5,542
Estimated static pressure (inches of water):	7.12
Estimated fan power needed (hp):	10.34

Fan Selection [Show Fan Data](#)

Select a fan:
 Fan arrangement: Parallel Series
 Number of fans on bin:

Results

- [Airflow vs Depth Table](#)
- [Airflow Graph](#)
- [System Graph](#)

<http://webapps.bbe.umn.edu/fans/>

Preferred Duct Spacing

Drying

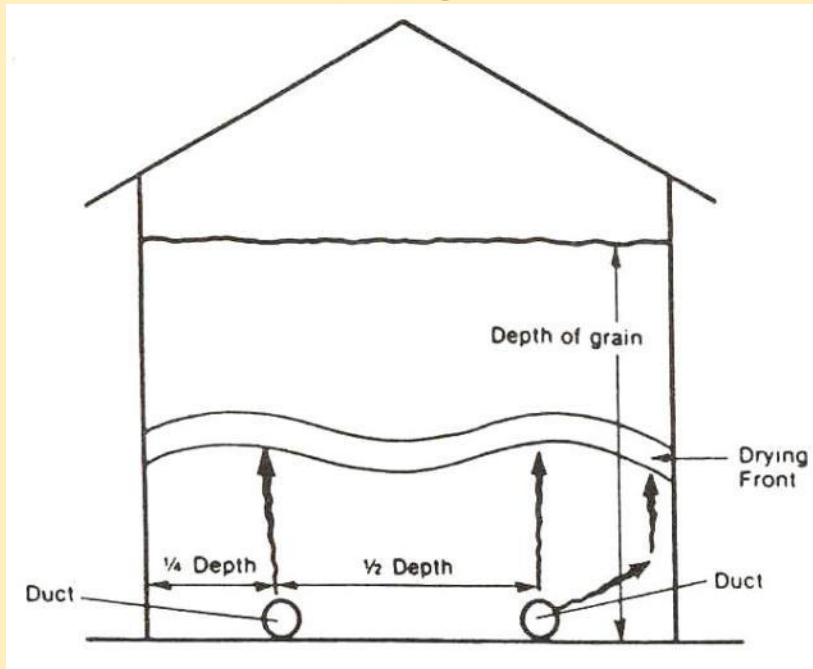

Aeration

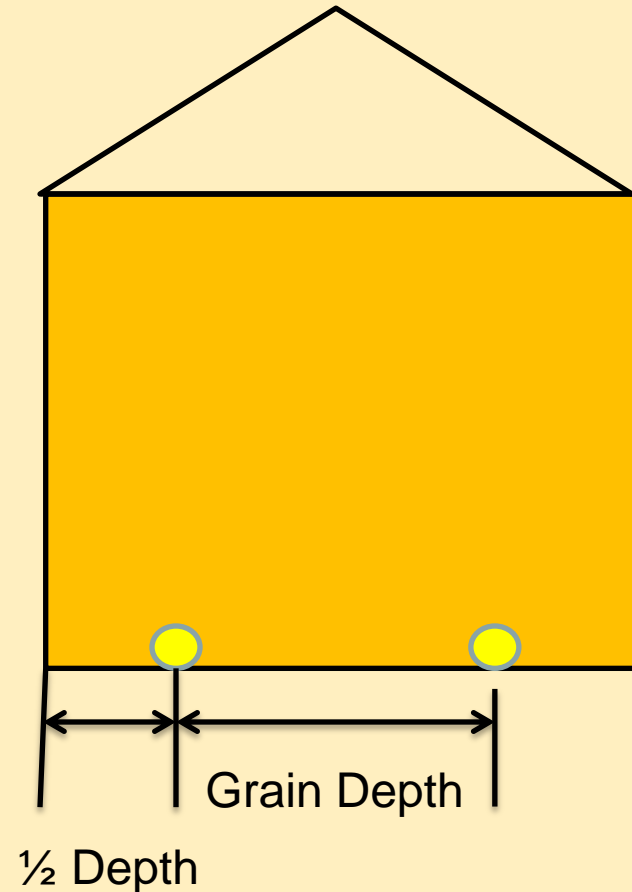

NDSU
Extension Service

Fronts Using Air Ducts

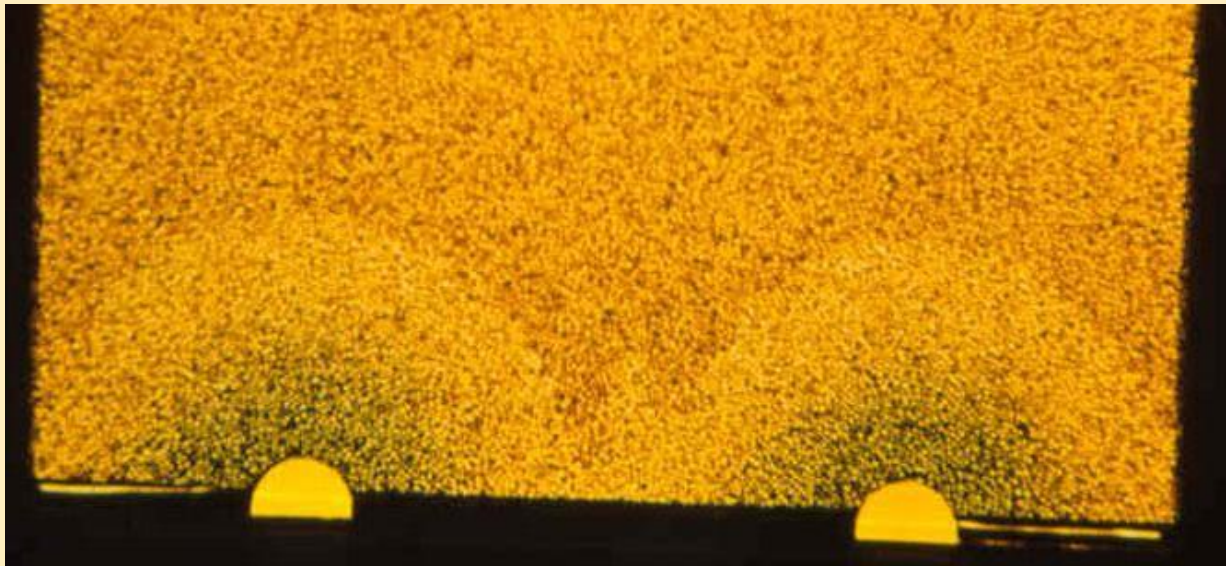

**Airflow is not uniform!
Both between and along ducts.**

Perforated Floor Preferred



NDSU
Extension Service

Level Bins for Uniform Airflow

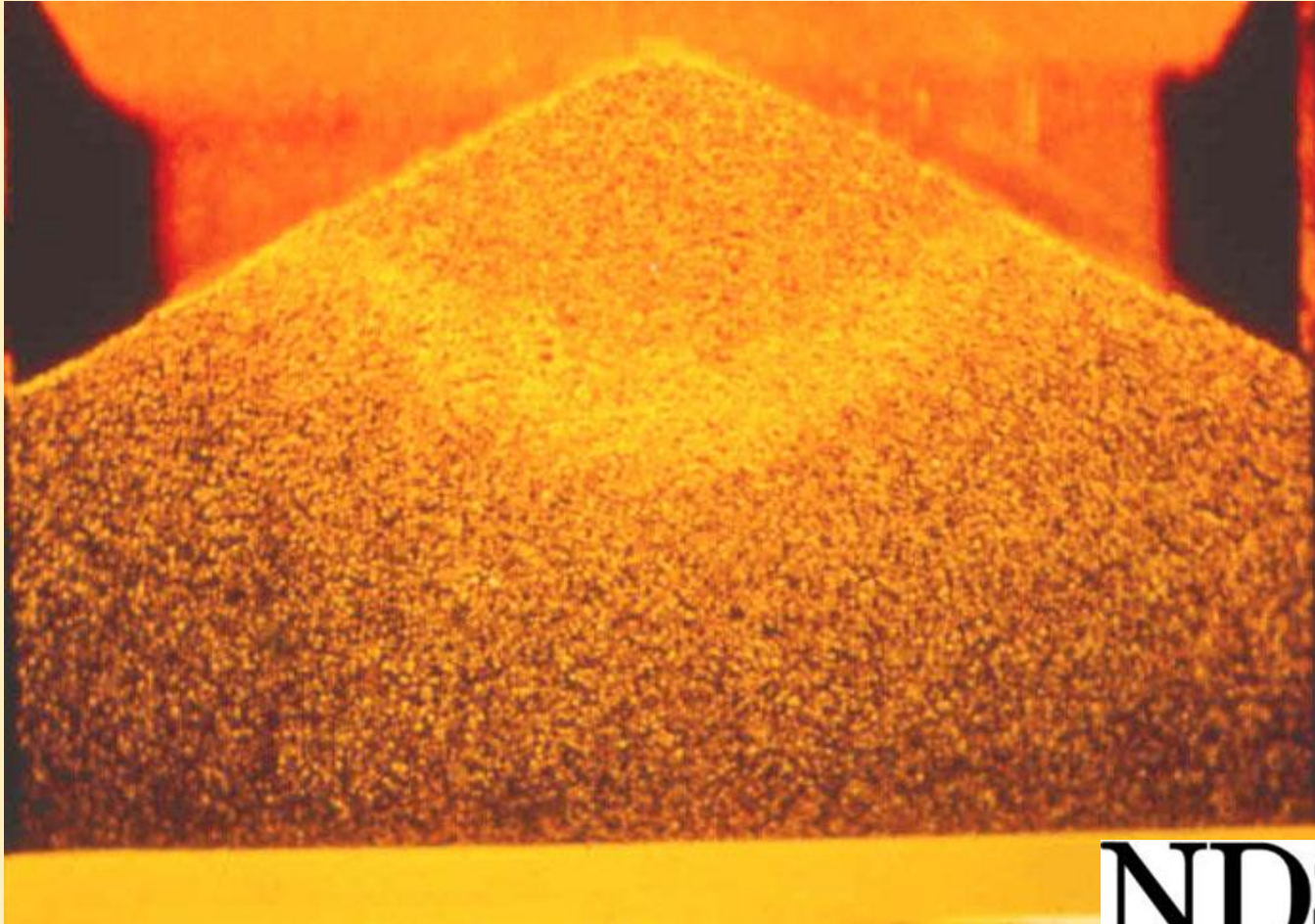

NDSU
Extension Service

High Temperature Dryer

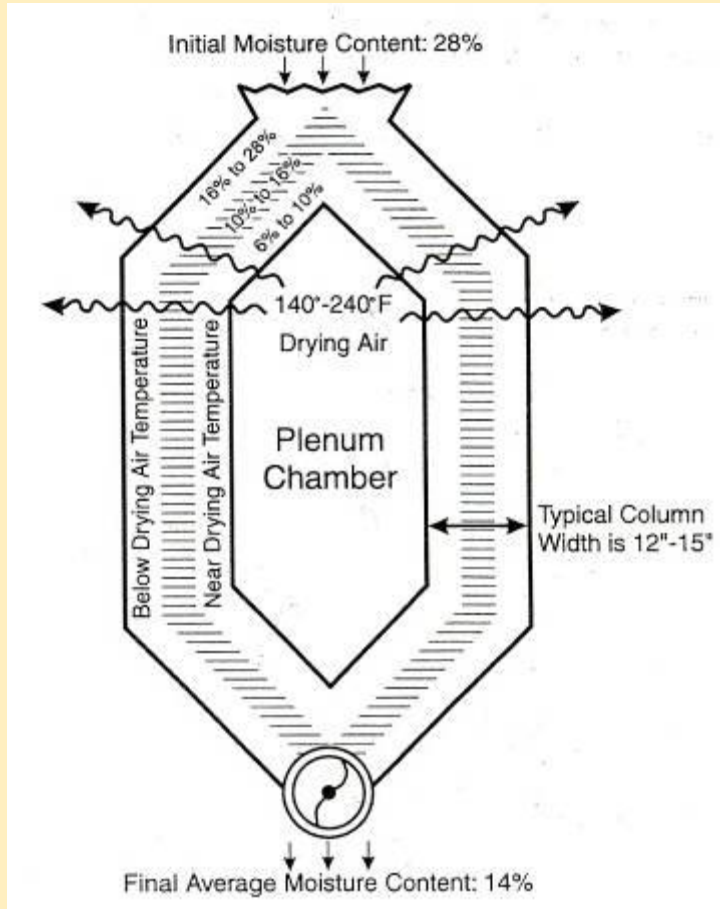

Maximum temperature to maintain germination $\approx 110^{\circ}\text{F}$

Drying Temperature and Time Affect Quality

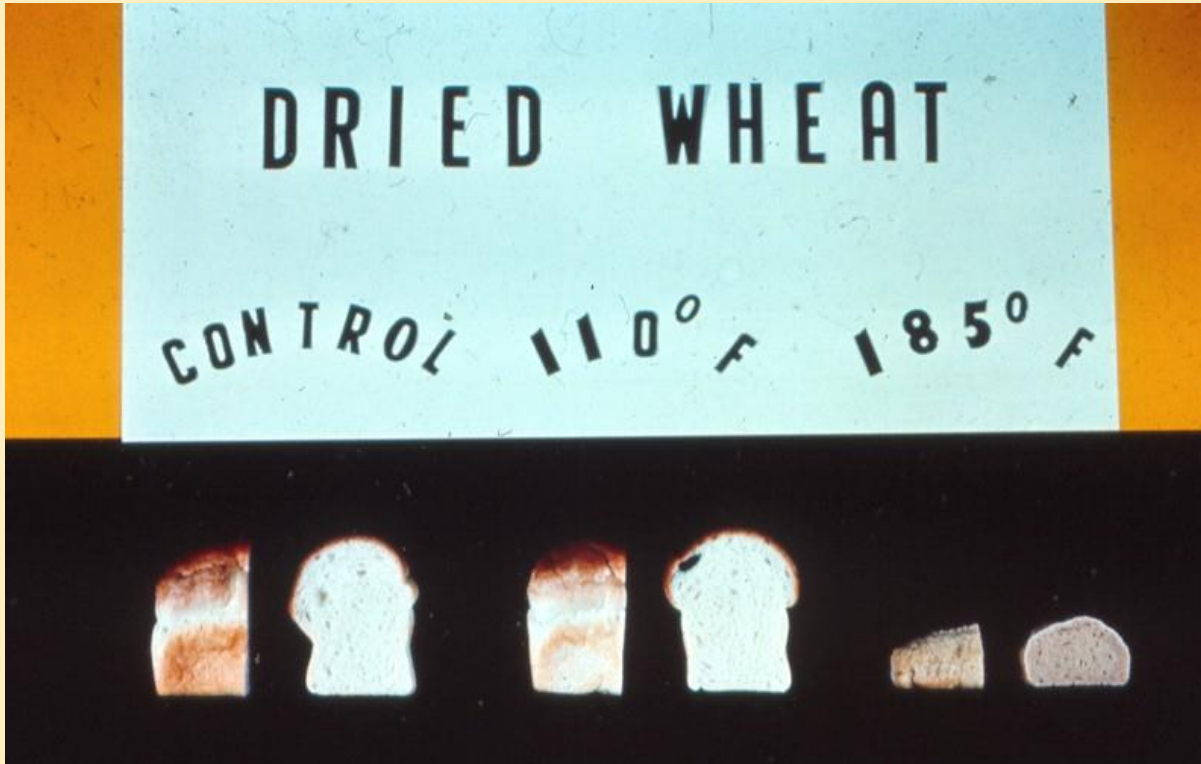

Maximum dryer temperature is about 150°F for 16% and 130°F for 20% moisture wheat.

For More Information



Internet Search: NDSU Grain Drying & Storage

NDSU
Extension Service
North Dakota State University



**Helping You
Put Knowledge
To Work**

Department of Agricultural and Biosystems Engineering